



HOSHIZAKI

FM-150KE-N

Nugget Ice Maker

PRODUCT FEATURES

- "Freeze Burn" is no longer an issue when displaying fresh fish or produce.
- Carbon auger bearings have a longer life expectancy than roller bearing, reducing maintenance costs.
- One piece bin moulding - rounded corners for hygiene and ease of cleaning.
- Automatic flush function, helps keep the ice making system clean.
- Integrated door handle for ease use and hygiene.
- Controller board with Operational Status display assists in troubleshooting.
- Due to the auger system, water consumption is equal to ice production.
- 2 year parts & labour on entire unit, 5 year (parts only) on compressor & air cooled condenser coil.



SHAPE OF ICE:

TECHNICAL DRAWING

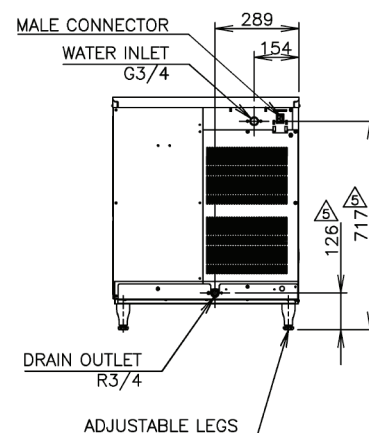
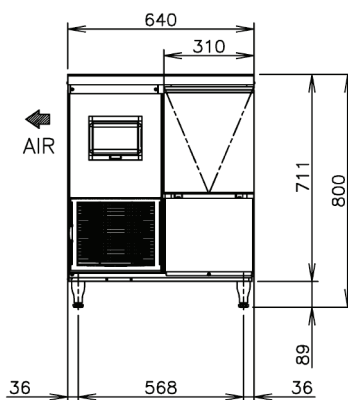
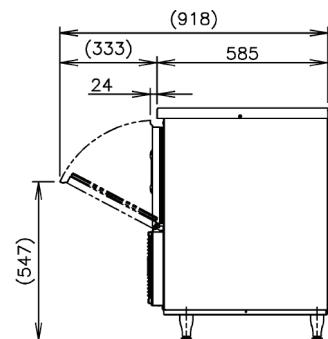
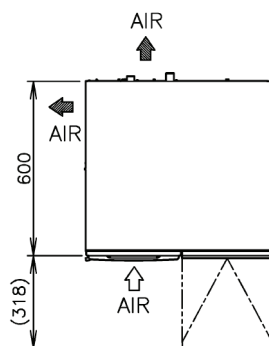

PRODUCT SPECIFICATION

Production Capacity per 24hours	Approx. 140kg @10°C Air temp; 10°C Water Approx. 120kg @ 21°C Air temp; 15°C Water Approx. 100kg @ 32°C Air temp; 21°C Water
Max Storage Capacity	Approx. 32kg
Dimensions	640mm (W) x 600mm (D) x 800mm (H)
Cooling	Air
Weight Net/Gross (kg)	71 / 82
AC Supply Voltage	1 PHASE 220-240V 50Hz / 10AMP Plug
Amperage	Running: 5.1A Starting: 20A
Refrigerant Charge	R134a / 200g
Operating Conditions	Ambient Temp.: 5-40°C Water Supply Temp.: 5-35°C Water Supply Pressure: 0.05-0.8MPa Voltage Range: Rated Voltage ±10%



Descriptions and specifications are subject to change at any time, without notice. Illustrations for demonstration purposes.

Copyright © 2020 Hoshizaki Lancer Pty Ltd. All right reserved. E&OE Date: Sept 2020